

Vulc-O-rings® and O-ring Cords

Vulc-O-rings

One of our oldest and most popular products is the Hot Vulcanised Cord ring ('Vulc-O-ring').

Eriks has developed a very successful method of producing O-rings from extruded cord to a very high technical standard.



The most important factors affecting the quality of this product are the mechanical characteristics and dimensional accuracy of the extruded cord stock. Over recent years Eriks has formulated special compounds which give very low compression set figures which are critical for high quality vulcanising.

In addition to this the in-house extrusion lines are all laser controlled for dimensional accuracy and the standard extruded finish cord tolerances are often tighter than DIN 7715 E1.



Eriks offers the optional 'close-tol' cord which can have the incredible tolerance of just +/- 0.05mm (0.002") and a super smooth surface finish.

Joint Tensile Strengths

As the opposite picture shows, Eriks produces all joints by scarfing at 45°. This is very important in achieving high tensile strengths as the area of the vulcanising surface is greatly increased.

Eriks routinely conducts tensile strength tests on a regular basis to satisfy internal quality control requirements. In addition to this (by prior arrangement) production batch testing can also be provided.

The testing is carried out on a custom built tensometer.



A typical joint sample is 140mm long and is held in specially designed clamps.



Vulc-O-rings® and O-ring Cords

Joint Tensile Strengths

The joint sample is stretched until breakage occurs and, depending on material, can result in a very high elongation.



When the sample breaks it is often at the joint area. This does not infer weakness but at such high elongation, a surface imperfection around the joint area will be the point of breakage.



The break as you can see is at the joint area but at 90 degrees to the cord stock.

This detail shows that the vulcanised area has not failed and indicates a good quality vulcanisation.



After breakage the load cell transfers to computer software the data which is then analysed and expressed in graph form and as industry standard Mpa tensile strength.

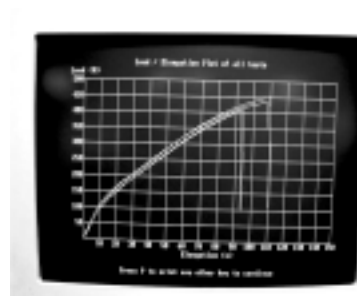

It is then possible to include this testing with general certification (by prior agreement).

By conducting joint tests and inserting them into the actual production schedule, Eriks can obtain a true representation of the integrity and consistency of the vulcanising process, particularly useful on higher volume orders.

Vulc-O-rings® and O-ring Cords

Size Range

ERIKS can produce Vulc-O-rings with cross sections ranging from 1.78 mm to 15.9 mm (perhaps larger by special request). These will have a surface finish as extruded unless otherwise requested.

Unlike moulded O-rings, Vulc-O-rings have a limit as to how small an inside diameter that can be produced, which is regulated by the cross section. The following table shows the smallest sizes that can be produced.

Cross section Ø	Smallest Inside Ø
1.78 mm - 8.40 mm	30 mm
9.00 mm - 12.70 mm	45 mm
13.00 mm- 15.90 mm	60 mm

Please note the price list for these small size Vulc-O-rings are more expensive because they are more difficult to manufacture.



There is however no upper limit to diameter.

The largest Vulc-O-ring Eriks has ever produced so far has been an amazing 22 meters in diameter! The only difficulty is checking the inside diameter at quality control!

Dimensional Tolerances

As previously mentioned, Eriks' extruded cord is unrivalled for tolerance control. Standard extruded cord better E1 in many sections and a summary of the standard sections with their tolerance follows:

Ø	Tol.	Ø	Tol.
1.78	± 0.10	6.50	± 0.25
2.00	± 0.10	6.99	± 0.25
2.40	± 0.12	7.50	± 0.25
2.62	± 0.12	8.00	± 0.25
3.00	± 0.12	8.40	± 0.25
3.18	± 0.15	9.00	± 0.25
3.53	± 0.15	9.52	± 0.25
4.00	± 0.15	10.00	± 0.33
4.50	± 0.20	11.10	± 0.38
4.80	± 0.20	12.00	± 0.45
5.00	± 0.20	12.70	± 0.45
5.34	± 0.20	13.00	± 0.45
5.50	± 0.25	14.00	± 0.50
5.70	± 0.25	14.30	± 0.50
6.00	± 0.25	15.00	± 0.50
6.35	± 0.25	15.90	± 0.50

Every inch of the extruded products are checked for compliance to the above tolerances by state of the art 'laser micrometers'. This is the only way to guarantee 100% cross section diameter inspection.



Each batch of extrusion is passed through one of these laser micrometers and the laser measures the cord 250 times per second and then produces a report after each batch showing details of high, low, and average diameters.

Vulc-O-rings® and O-ring Cords

Inside diameters are controlled according to DIN 7715 M2F as Vulc-O-rings frequently fall outside the range of diameters controlled by BS or AS standard sizes.

Inside diameter	Tolerance
25mm thru 40mm	+/- 0.35
40.1mm thru 63mm	+/- 0.40
63.1mm thru 100mm	+/- 0.50
100.1mm thru 160mm	+/- 0.70

Hereafter the tolerance will be +/- 0.5% of the nominal inside diameter of the ring
 Example: inside diameter of 310.0mm tolerance = +/- 1.55mm (0.5%)

Benefits of Vulc-O-rings

The main benefits of utilising Vulc-O-rings are listed as follows.

- Molds are not required resulting in huge cost savings
- No upper diameter restrictions like molding
- Tolerances can be closer than molding
- No flash lines are present
- Can be used in standard housings
- Shapes other than round are possible
- Joints in some cases 90% of cord strength
- Short lead times (48 hour turn around possible)

Restrictions of Vulc-O-rings

There are however areas where Vulc-O-rings are restrictive.

- Dynamic applications where roll may occur.
- Excessive stretching- low strength materials.
- Not possible below hardness of 60 Shore A.
- Not competitive against moulded rings when small diameters in high volume.

Lead Times for Vulc-O-rings

Price list Vulc-O-rings up to 100 pcs will be shipped within seven working days from receipt of order. Other volumes and sizes are available based on the application.

Materials

ERIKS maintains a standard range of materials in compound form for speedy conversion into extruded cord. This is a different policy than of holding cord on the shelf. There are more and more clients asking for current quarter cure dates and this policy ensures that the user gets this rather than cord which may have been on the shelf for longer.

Other materials, colors and hardness's may be possible to special manufacture. Contact ERIKS with any requirements.

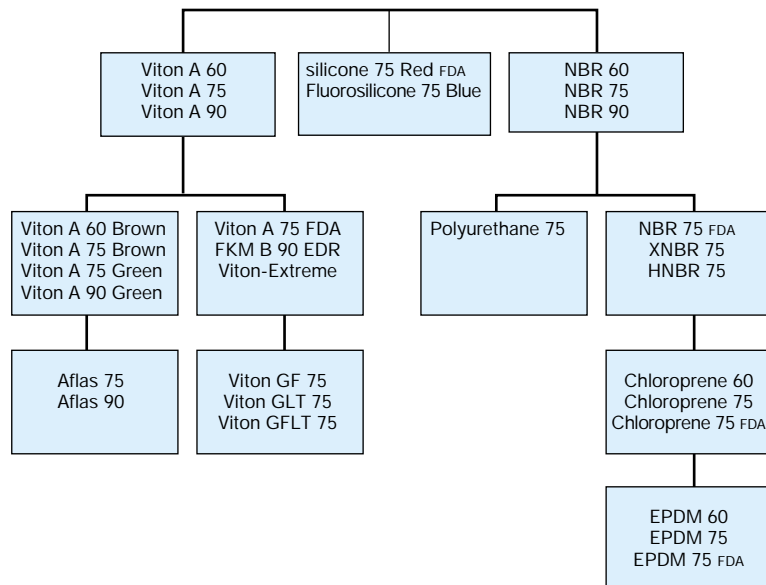

Vulc-O-rings® and O-ring Cords

16.2 Rubber O-ring Cord

The table shows the available stock cord dimensions and elastomers. Upon request cord in special elastomers or special dimensions can be supplied.

Available materials:

Nitrile NBR 70° shore A, NBR 90° shore A, Fluorocarbon FKM 70° shore A, FKM 75° shore A, Neoprene CR 60° shore A, EPDM 70° shore A, Silicone MVQ 60° shore A, Polyurethane AU/EU 90° shore A, and Para NR 40° shore A. Other elastomers, hardnesses, or special colors can also be supplied.

An O-ring splicing kit is available with the materials required for cold bonding of custom size O-rings.

Please note that vulcanized or spliced O-rings are only recommended for static applications.

For full information ask for the special brochure: Vulc-O-rings® or contact the local ERIKS representative.

Rubber Cord

Cross section		NR Para	NBR Nitrile			Polyurethane	CR. Neoprene	EPDM	FKM fluorocarbon		MVQ Silicone		
inch	mm	40° sh	70°sh	90°sh	90°sh	60°sh	70°sh	70°sh	75°sh Original Viton	60°sh 714 BF FDA/BGA	60°sh 714 THT	60°sh 714 MP FDA/BGA	
		Tol.E2 brown	Tol.E2 black	Tol.E2 black	Tol.E2 green	Tol.E2 white	Tol.E2 black	Tol.E2 black	Tol.E1 black	Tol.E2 transp.	Tol.E2 grey	Tol.E2 grey	
.063	1,60		X				X	X					
.070	1,78		X				X	X					
.079	2,00		X				X	X		X			
.094	2,40		X					X					
.098	2,50		X							X			
.103	2,62		X				X	X		X			
.118	3,00	X	X	X	X	X	X	X	X	X	X		
.128	3,25		X										
.139	3,53		X	X		X	X	X	X	X			
.157	4,00	X	X		X	X	X	X	X	X	X	X	
.177	4,50		X					X					
.187	4,75							X					
.197	5,00	X	X	X	X	X	X	X	X	X	X		
.210	5,33		X				X	X	X				
.224	5,70		X				X	X	X	X			
.236	6,00	X	X	X	X	X	X	X	X	X		X	
.250	6,35		X					X					
.256	6,50							X					
.276	7,00	X	X		X	X	X	X	X	X	X	X	
.295	7,50		X										
.315	8,00	X	X	X	X	X	X	X	X	X	X	X	
.331	8,40		X				X	X					
.354	9,00	X	X			X	X	X		X			
.374	9,50		X										
.394	10,00	X	X		X	X	X	X	X	X	X	X	
.433	11,00		X				X	X					
.472	12,00	X	X			X	X	X	X	X	X	X	
.512	13,00		X			X		X		X			
.551	14,00		X			X	X	X					
.571	14,50					X							
.591	15,00		X			X	X	X		X		X	
.630	16,00		X			X	X	X		X			
.669	17,00											X	
.709	18,00	X	X			X				X			
.787	20,00	X	X			X	X	X		X			
.866	22,00		X							X	X	X	
.906	23,00										X	X	
.984	25,00	X	X			X						X	
1.181	30,00		X			X	X						
1.220	31,00									X			
1.260	32,00		X										
1.575	40,00		X										

All hardness values were measured on the shore A scale.